

MAYDAY LMW2 Lone Worker Safety System

Specification.

The MAYDAY is a loneworker safety system. It is designed to give audible and visual warning to prompt staff to take action by cancelling a warning after a pre-determined period. Failure to take action will result in a secondary alarm operating after a further pre-determined period. This is used to raise an alarm to call for assistance which can be either a simple sounder and visual indicator or a voice message transmitted via a speech dialler (not supplied) via a landline. The two time periods are separately adjustable. 20 - 60 minutes and 2 - 10 minutes respectively. The MAYDAY is mains powered and supplied with a rechargeable 12v 0.8Ahr standby battery. The integral 12v power supply will deliver 150ma for ancillary items. The unit is housed in a plastic enclosure approx. 125w x 175h x 55d (mm).

The MAYDAY has the following integral indications and controls:-

1. An On Off keyswitch to arm the unit.
2. An OK button to restart the countdown timer and reset the alarm.
3. A green Power On LED.
4. Four red System Active countdown LEDs.
5. An integral piezo sounder. (85db at 10cm)
6. Two adjustable countdown timer controls. These are fitted internally and only used during the installation set-up.

Five inputs are provided for connecting ancillary devices:-

- IN1** Remote OK buttons to supplement the front panel OK button. (Normally Open -close to acknowledge OK)
- IN2** To arm the MAYDAY from a keyswitch or other device. (Normally Closed - open to start lone working)

IN3 Input from a movement detector such as a PIR (Normally Closed -open on detection -ie OK)

IN4 Input from a speech dialler. (Apply a -ve for OK)

IN5 Timer set-up. This is a divide by 60 facility (eg 57mins= 57sec).

Volt free contacts are provided by three independent relays:-

Relay 1 operates when the keyswitch is thrown to arm the unit.

Relay 2 operates at the end of the first pre-determined run down delay **T1** (20-60 minutes).

Relay 3 (normally on, off when operated) operates at the end of the second pre-determined countdown delay **T2** (2-10 minutes).

Eight outputs are provided for remote indications:

LED1 - 4 follow the LEDs on the front panel.

LED5 Remote buzzer, follows internal buzzer

LED6 Remote LED, all indications.

LED7 Remote LED to indicate T2 has run out.

LED8 Remote power LED.

Timer set-up procedure.

With IN2 closed (or keyswitch OFF), link out IN5, LED's 2 and 4 only illuminate. Set T1 and T2 pots approx. (Best guess). Press the OK button, the unit beeps and leds 1 and 3 only illuminates for T1 time in seconds. At the end of T1 the unit beeps and leds 1 and 2 only illuminate for T2 time in seconds. At the end of T2 the unit beeps and reverts to leds 2 and 4 only. Adjust the pots accordingly and repeat until time T1 and T2 minutes are correct as indicated in seconds. Remove the link IN5 and the unit is set to operate in minutes.

Loneworker Scenarios where MAYDAY could be used

The notes below will assist in deciding how MAYDAY and ancillary equipment should be used and configured for any particular situation. The first consideration should be; where are the responders located?

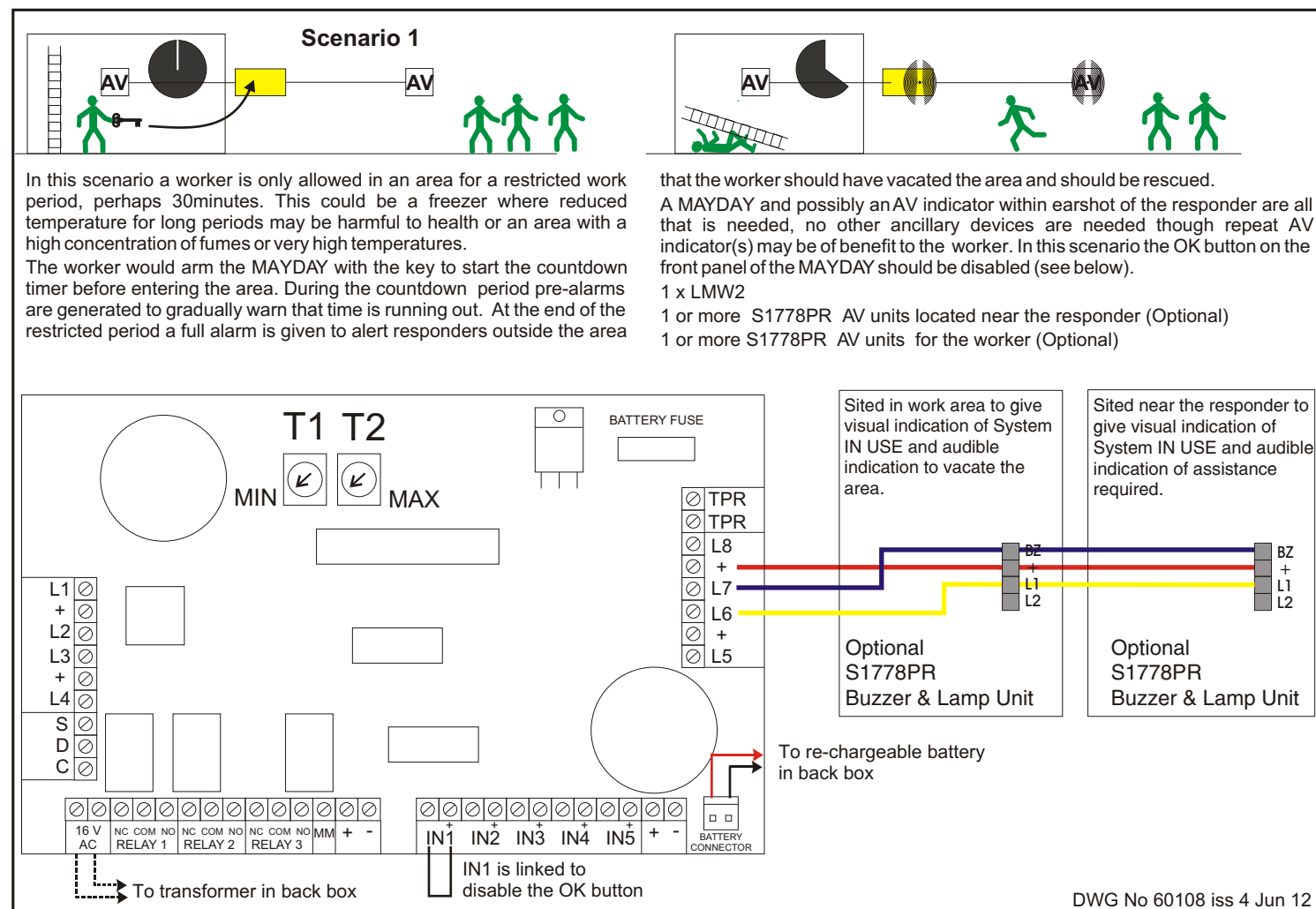

DWG No 60108 iss 4 Jun 12



Hoyles Electronic Developments Ltd

T. 01744 886600

F. 01744 886607

E. sales@hoyles.com

W. www.hoyles.com

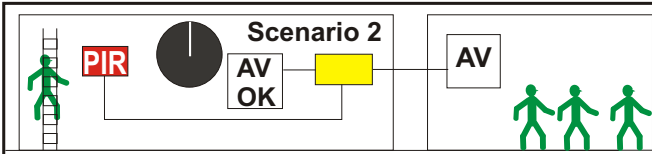

The working practice in force here allows lone working for long periods of time. It could be a full 8 hour shift but on a remote part of a site. The responder(s) could be some distance away but on the same site.

The worker would arm the MAYDAY to start the countdown timer. Pre-alarms are generated in the same way as in 1 above. Periodically the worker presses an OK button to restart the countdown timer. If the worker does not, then eventually the MAYDAY generates a full alarm at a remote audible/visual indicator AV to alert the responder.

A MAYDAY and an AV indicator within earshot of the responder are all that

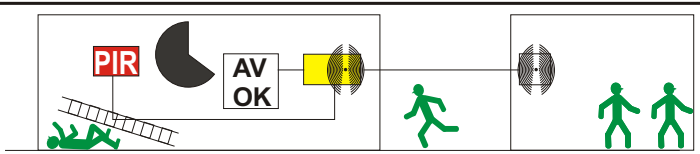

is needed, no other ancillary devices are needed though a repeat AV indicator(s) with OK acknowledge buttons may be of benefit for the worker depending on the size of the working area. An alternative to an OK button would be one or more Passive Infra Red detectors, this could allow for hands free operation.

1 x LMW2

1 or more S1778PR used as AV units located near the responder

1 or more S1703PR or S1708PR used as AV/OK buttons (Optional) and/or PIRs (Optional) for the worker.

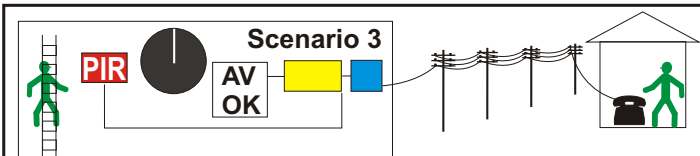
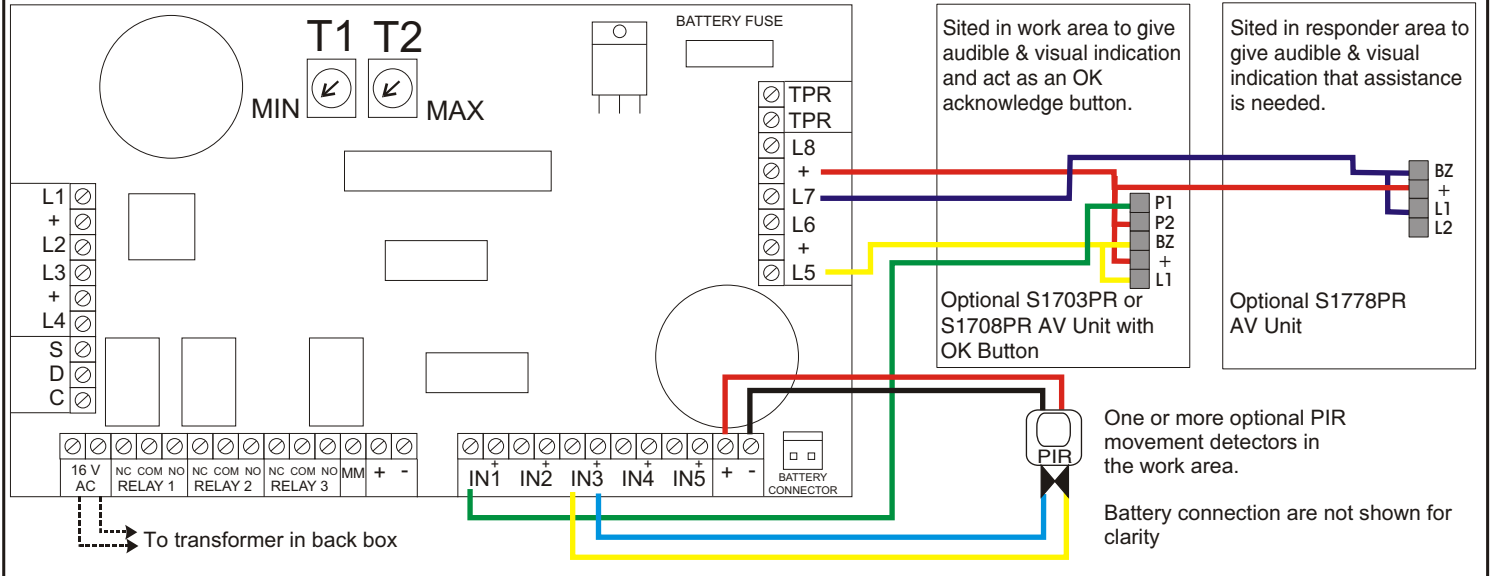

The working practice here and operation is the same as 2 above but the responder(s) is remote from the site.

The communication to the responder uses an auto-dialler via a landline. Signalling can also be given for the start and end of lone working. Up to three responders telephone numbers can be programmed into the dialler. Each is dialled in turn until acknowledge by the responder dialling 8. A fourth number can be programmed for the lone worker. If no responder acknowledges then the lone worker is automatically called to advise that he/she will be working alone without cover. A separate landline or mobile is required for this return call.

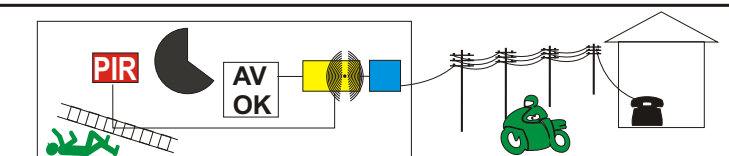

A MAYDAY and an auto-dialler are needed, no other ancillary devices are needed though one or more OK/ AV buttons may be of benefit to the worker. An alternative to OK buttons would be one or more Passive Infra Red detectors, this could allow for hands free operation.

1 x LMW2

1 x SD1E Autodialler to contact the responder

1 or more S1703PR or S1708PR used as AV/OK buttons and/or PIRs for the worker.

1 x Mobile phone for the worker (Optional)

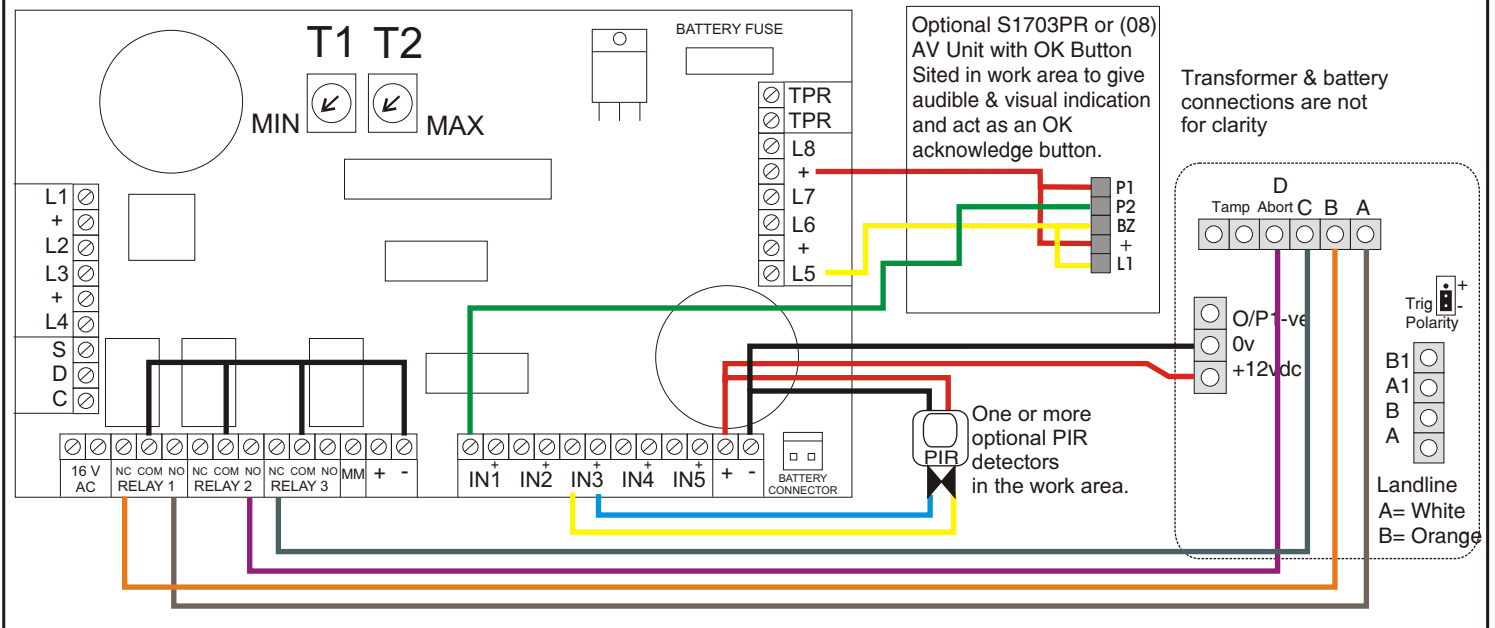



If an auto-dialler SD1E is used for communication as in scenario 3 then it is possible to use the communication link to enable the worker to use a mobile phone to generate an OK signal to restart the countdown timer. This would enable say a patrolling security guard to cover a large site without the need for dozens of hardwired OK/AV acknowledge buttons. Optional OK/AV buttons can be used if necessary to enable the countdown timer to be reset.

Towards the end of the countdown period the MAYDAY generates a signal to cause the auto-dialler to call the worker's (guard's) mobile phone. The worker answers and responds by pressing a predetermined key on his

phone. This tells the autodialler to send a signal to the MAYDAY to restart the countdown timer. If no signal is received then auto-dialler calls the responder to alert him to a problem on site.

Such a system requires:-

- 1 x LMW2
- 1 x SD1E auto-dialler
- 1 x Mobile phone
- 1 or more OK/AV buttons (Optional)

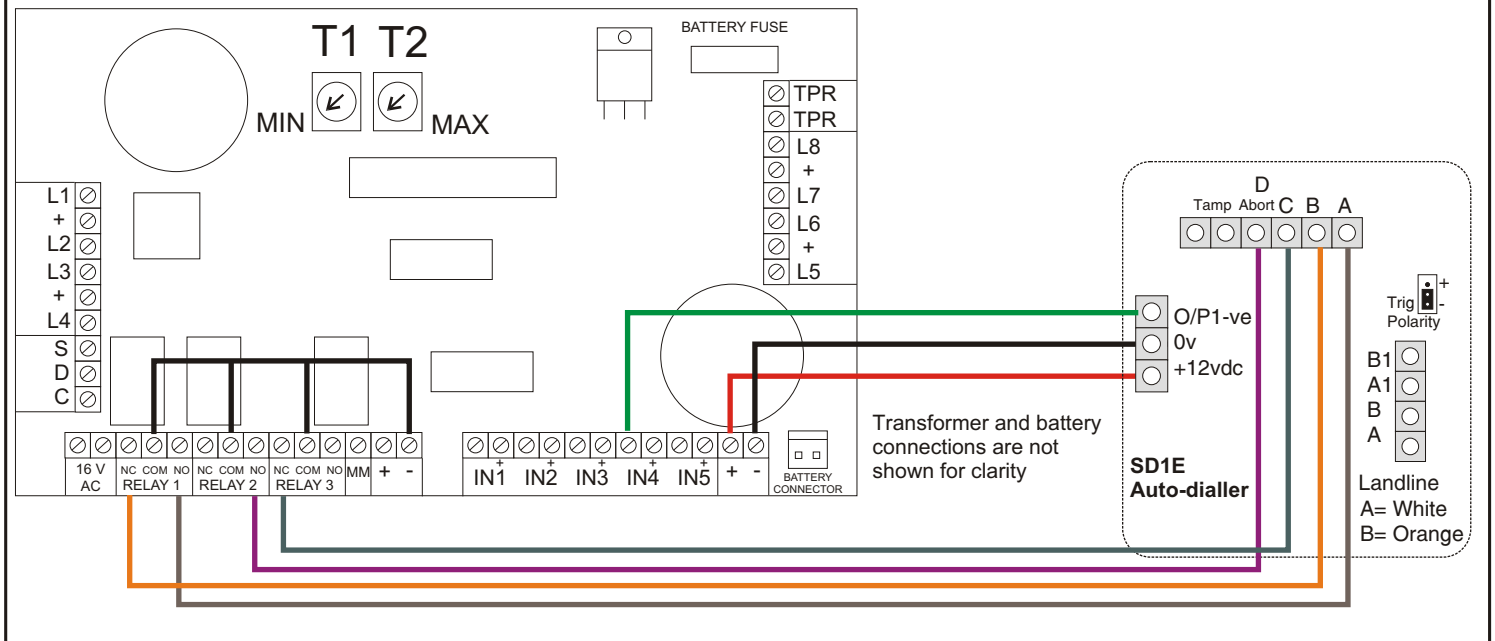

Operation.

1. The green mains on LED is illuminated at all times unless the mains has failed.
2. When the keyswitch is thrown to activate the arm the MAYDAY the four red System Active countdown LEDs adjacent to the OK button illuminate and the countdown timer T1 starts. If the keyswitch is used to switch off at any time then no further timing or other action takes place. (This would be the case for scenario 1 above)
3. When armed the Lone Worker is expected to periodically press the OK button on the MAYDAY or an ancillary OK/AV button within the workplace. Alternatively if a movement detector is used to sense movement within the workplace then no action other than movement is required by the worker.
4. If the OK button or a remote OK button is pressed, the panel buzzer will bleep to acknowledge this. If a PIR movement detector senses movement with the workplace then the countdown timer is reset without any bleep. This minimises annoyance when moving around constantly.
5. As the countdown timer runs down the four LEDs gradually extinguish to give a visual indication of time remaining. As each LED extinguishes a bleep is heard.
6. At the end of the first countdown period only one LED remains

illuminated and the bleeps become more frequent during the second countdown period to warn the lone worker that action must be taken to reset the countdown timer by pressing an OK button or in the case of scenario 4 he/she will be called by mobile phone to dial 8 as an OK

7. If no action is taken before the end of this second countdown then a full alarm condition is raised. This may be an AV device on the same site to call the responders (Scenario 2) or a message from a speech dialler to call a remote responder. (Scenario 3 or 4)

8. Under mains fail condition the green power on LED will extinguish.

9. If the mains have failed prior to arming then, on arming, the green power LED will flash for a short period and then extinguish. The MAYDAY will continue to function but the four red countdown LEDs will flash.

10. If the mains fails after arming then the MAYDAY will behave as though the primary countdown timer has run down and only a short period remains before an OK button should be pressed. The MAYDAY assumes that there is a possibility that the cause of the mains failure could be the lone worker.

The above conditions assume that the rechargeable standby battery is healthy.



Hoyles Electronic Developments Ltd

T. 01744 886600

F. 01744 886607

E. sales@hoyles.com

W. www.hoyles.com

Speech dialler setup for MAYDAY lone worker alarm

The notes below are our recommended set up for use with a MAYDAY lone worker alarm when connected in accordance with our installation instructions. If you wish to set the SD1E differently then you should consult the installation and operation manuals supplied.

The SD1E is a 4 channel 4 number speech auto-dialler. (The SD1E operators manual refers to channels as trigger inputs). The channel inputs are A,B,C and D. Channel D is factory set as an abort channel and needs to be re-programmed as a message channel (see 7 below). Each channel can give a different message. In the notes below a message is composed of two phrases, a common phrase and a channel specific phrase. The common phrase is referred to as phrase O and the channel phrases as A,B,C and D. Refer to the table below for an example of recommended phrases. Write your own phrases in a similar table before you start recording. You have a total of 40 seconds to record all 5 phrases. It is recommended that all messages be recorded in order in one session, to avoid trying to fit a spoken message into a predefined time slot.

Throughout these instructions the keypad presses are denoted in bold capitals eg **ENT**. The LCD display readings are denoted in bold italics eg **READY**

1. If this is a first time install short circuit the Factory Restart pins JP2 whilst applying 12vdc power. This erases the memory of all phrases, numbers and other set up parameters. The unit should bleep and display **PLEASE RECORD**. Complete all programming before connecting the BT line.

2. Next enter the PASSCODE '1234'. The display should read **READY**.

3. You must now record at least one message.

3.1. Press **ENT**. The display will alternate between: **ENT 1-4 : OR O-D**. Press **0** and the display will read **RECORD PHRASE 0**. (The **1-4** is for the telephone numbers see later). Phrase 0 is the common phrase and will be announced first in each message.

3.2. To record the phrase press **ENT** and the display shows **REC-40**, and starts to count down. Speak your phrase into the integral microphone of the SD1E. When you have recorded the phrase, press **ESC**. This will stop the timer and the display will again alternate between **ENT 1-4 : OR O-D**. waiting for you to record the next phrase.

3.3. Record the phrases one at a time, To record the A phrases, press **A**, the display will read **RECORD PHRASE A**. Press **ENT** and the display will show **REC** and the remaining time. Press **ESC** at the end of phrase A. While recording, the total time remaining will be displayed.

3.4. Record phrase B by pressing **B** and repeating the procedure 3.3 above.

3.5. Press **ESC** to get back to **READY** display.

4. Next programme the telephone numbers.

4.1. From the **READY** display, press **ENT** the display will alternate between: **ENT 1-4 : OR O-D**, press **1** to programme the first telephone number to be dialled followed by the telephone number, including any access codes for PABX system, and press **ENT**. The display will revert to alternating between: **ENT 1-4 : OR O-D**. Press **2** to programme the second telephone number to be dialled followed by its number. Repeat the process for number 3. Number 4 is usually made available for the lone worker's phone from which he/she can acknowledge and reset the MAYDAY. If you get a digit wrong, press the **A** button to correct.

4.3. Press **ESC** to get back to **READY** display.

5. Next set up the SD1+ output to acknowledge the Mayday.

5.1. From the **READY** display press **6**. The display should read **OUTPUT**. Press **ENT** the display should read **ACTIVE**. Press **B** until the display reads

SUCCESS and then press **ENT** the display should read **READY**.

This must be used if the Mayday calls the lone worker's mobile phone to be acknowledged and reset the MAYDAY timers.

6. Next set up the call routing. Which numbers to call for a particular channel.

6.1. From the **READY** display press **7** the display should read **ROUTE**- Press **ENT**. The display should read **A>1234**. Press the numbers 1,2,3 or 4 to toggle the display numbers on or off as required. In a typical setup telephone numbers 1, 2 and 3 may be toggled off for channel D, thus the display would read **D>4**. This is the only number that will be called when channel D is triggered. The message sent will be the common phrase O plus phrase D

6.2. When you are satisfied that the numbers are correct for channel A the remaining channels **B>1234**, **C>1234** and **D>1234**, can be scrolled through by pressing button **B**. They are set up by toggling as in 6.1 above. When all are set press **ENT** and the display should read **READY**.

6.3. We recommend that channels A,B and C call each of the four numbers 1,2, 3 and 4. Channel D should be reserved for calling the lone worker's phone when the unit requires to be acknowledged. Thus the routing for channel D should read **D>4**

7. Next set up the ABORT input channel as channel D. This allows the abort input terminal to be used as channel D and also the dialler to be reset by the passcode if no one is available to acknowledge its dialled numbers.

7.1. From **READY**, press **8**, the display should read **ABORT-**, press **ENT** and press **B** repeatedly until the display reads **PASSCODE**. Press **ENT** and the display should read **READY**.

8. Next set up the acknowledgement to stop the dialler from repeatedly dialling.

8.1. From **READY** press **0** and the display should read **CLRBYP**- press **ENT** and then the display should show how many acknowledgements are required to stop the dialler re-dialling. Press the **B** button repeatedly until you see the number that you require, (we recommend '**ANY-1**') and then press **ENT**. The display should go back to **READY**.

If you select the **NO-ONE** option the SD1E will continue to call if numbers are engaged or not answered but will stop when one is answered even if by an answering machine. **The NO-ONE is therefore not recommended.**

While it is possible to dial to a pager, it is not recommended, as the pager has no acknowledge or return call facility. The acknowledge facility, requires the called person to press **8** to acknowledge. For this reason your message should include the words "**press 8 to acknowledge**".

9. To erase the messages and start again.

9.1. From **READY**, press **ENT**, the display will alternate between: **ENT 1-4 : OR O-D**. Press **ENT** again, the display should read **ERASE-**. Press **B** the display should read **SPEECH** press **ENT** and the display should revert to **ENT 1-4 : OR O-D**. Press **ESC** to return to **READY**. All phrases now need to be re-recorded, see 3 above.

10. To erase telephone numbers. (assuming you are in programme mode)

10.1. From **READY** press **ENT**. The display will alternate between: **ENT 1-4 : OR O-D**. Press **ENT** again and the display will show **ERASE-** press **B** twice to scroll the display to show **PHONES**. Press **ENT** to accept and the display should revert to **READY**. You will now need to re-programme the numbers as in 4 above.

Pressing **ESC** from display **READY** should display **SD1+**. To get back to the **READY** display, enter the passcode **1234**. To return to the **SD1+** wait for 60 seconds or repeatedly press **ESC**. Other options such as changing the passcode or setting up the BT line as pulse or tone should be done from the SD1+ operating manual.

Phrase O	XYZ Ltd. Newtown	
Phrase A	Lone working has started. Please press 8 to acknowledge you are on call.	
Phrase B	Lone working has stopped. Please press 8 to acknowledge.	
Phrase C	Lone worker in difficulty. Please press 8 to acknowledge you will attend.	
Phrase D	Only press 8 if you are not in difficulty and you are the correct recipient of this message.	
Message to	Name	Telephone Number
1 st Aider No. 1		
1 st Aider No. 2		
1 st Aider No. 3		
Wandering Lone Worker only		