

Features

- ✦ 3 classes programmable.
- ✦ Reed switch testing.
- ✦ The fire LED allows 360° viewing.
- ✦ Output terminal for remote indicator available.
- ✦ Complying with EN 54-5.

Description

DC-9103E Conventional Rate of Rise and Fixed Temperature Heat Detector is a new generation product of GST. With built-in microprocessor, it works stably by being fixed with highly reliable fire judging program.

On detecting a fire signal, it can change its own current to transmit the signal to fire alarm control panel (FACP) or addressable zone monitor unit. The detector keeps illuminating fire LED until it is reset by power-down.

Connection and Wiring

The detector bottom is shown in Fig. 1 and the base in Fig. 2.

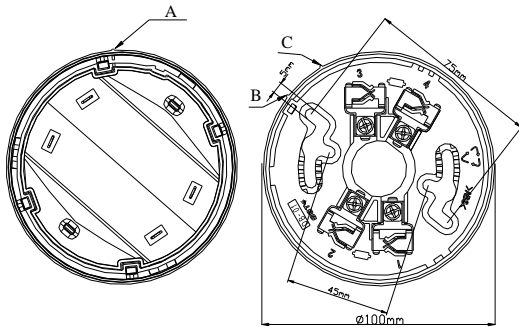

Fig. 1

Fig. 2

There are four terminals with numbers on the base.

- 1: Detection zone positive IN
- 2: Detection zone positive OUT
- 3: Detection zone negative IN and OUT
- 2: Positive terminal of remote indicator
- 4: Negative terminal of remote indicator

Recommended Wiring

1.0mm² or above fire cable for all terminals laid through metal conduit or flame retardant conduit, subject to local codes.

Note: It's recommended to use cables of different colors to avoid incorrect wiring.

Installation

First fix the orientation base with two tapping screws. Then align A (Fig. 1) on the bottom of the detector to B (Fig. 2) of the base, and rotate the detector clockwise to mark C.

Mounting of the detector is shown in Fig. 3.

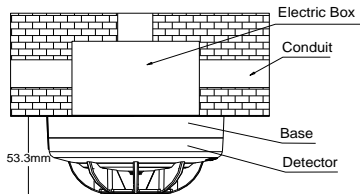

Fig. 3

Application

Warning: The alarm current depends on the current limit of the FACP. 24VDC power cannot be applied to the detector directly. Otherwise the detector may be damaged for lack of current-limit resistor.

The default class of the detector is A1R and polling LED status is "ON" which can be modified using a handheld programmer.



0832-CPR-F0005
GST-0005-01
14



548c/03

When the programmer is in standby state, entering unlock password and pressing "Clear", it will be unlocked. Pressing *Function* followed by 4, there will be a "-" at the last digit. Entering different number corresponding to the parameters followed by "Program", there will be a "P" shown on the screen, indicating its class is programmed. Pressing "Clear" can clear the "P", and entering locking password followed by "Clear" will exit.

Table 1 Detector setting parameters

Parameters	Class	Polling LED Status
2	A1R	ON
3	A2S	ON
5	BS	ON
130	A1R	OFF
131	A2S	OFF
133	BS	OFF

Read Heat Detector Class: When the programmer is in standby state, pressing "Test", it will display address of the detector. Pressing "Up", it will display sensitivity level, device type and heat detector class in turn.

The detector is especially applicable to places where fire occurs with a sharp rise of temperature. Used together with smoke detectors, it can help to increase the reliability of fire detection thus reducing losses.

✦ When the detector is connected with compatible FACP or addressable zone monitor unit in series, if DP-9907 Active End of Line Unit (AEOL) is connected to the end of output loop, a DB-01D base should be used.

➤ If the AEOL is used as the detector base, a conventional detector can be installed on it. The system composition is shown in Fig. 4.

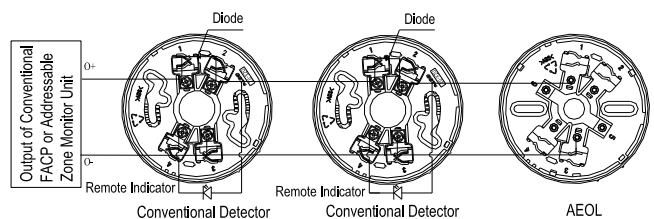

Fig. 4

➤ When the AEOL is not used as the detector base, a cover should be put on it. The system composition is shown in Fig. 5.

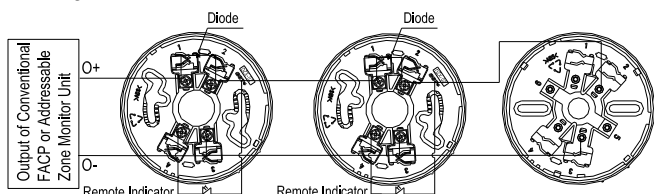

Fig. 5

- When the detector is connected with conventional FACP or addressable zone monitor unit, if a 4.7kΩ end of line resistor is connected to the end of output loop, DB-01 base is used. The system composition is shown in Fig. 6.

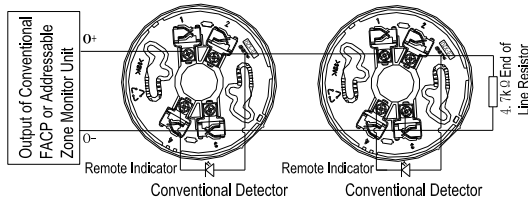

Fig. 6

- When multiple detectors are connected with a remote indicator, a diode 1N5819 should be connected to Terminal 4 of the orientation base in series before going to the positive of the remote indicator. System composition is shown in Fig. 7.

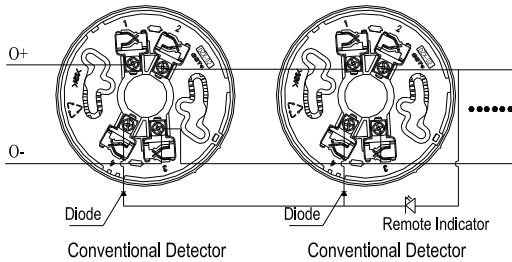

Fig. 7

Maximum 15 detectors can be connected to the output of zone monitor unit. In case of broken circuit or removal of any detector, the unit will transmit a fault message to the FACP. If and AEOL is connected, normal operation of other device in the system will not be affected.

Testing

Note: Before testing, make sure the detector is properly installed and powered up. Testing can only begin after the detector is powered up for 10 seconds.

The detector must be tested after installation and regular maintenance. The methods are as follows:

(1) Reed switch testing

The testing area of the detector is shown in Fig. 8.

Approach the commission tool to the testing area of the detector and hold for several seconds until the detector alarms.

(2) Temperature test

Approach a heater (such as a hair drier) to the thermistor of the detector until it alarms.

After testing, disconnect power to the detector for over 10 seconds to reset it. Notify the proper authorities that the system is back to normal operation.

If a detector fails in testing, clean it by the steps in "Maintenance", and retest it. If it still fails, return it for repair.

Maintenance

- The detector should be installed just before commission and kept well before installation, taken corresponding measures for dust-proof, damp-proof and corrosion-proof.
- The dust cover cannot be removed until the project has been plunged into usage.
- Clean the detector at least once a year to ensure normal operation of the system.
- Before cleaning, notify the proper authorities that the system is undergoing maintenance and will temporarily be out of service. Disable the zone or system undergoing maintenance to avoid unwanted alarms.
- The detector should be tested again after cleaning and re-installing.

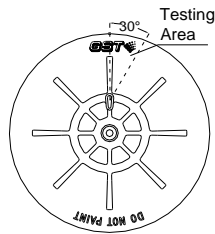

Fig. 8

- Protect the metal component on the PCB against damp and improper distortion.
- Do fire simulation test at least once every 6 months.

Specification

Operating Voltage	24VDC(16VDC~28VDC)
Standby Current	≤60μA
Alarm Current	≤55mA
Fire LED	Red, periodically flash once in polling when the status is set to "ON"; don't illuminate when the status is set to "OFF". Periodically flash twice in fault; illuminate in alarming.
Remote Indication Output	Polarity-sensitive, directly connecting with remote indicator (built in 10k resistor in series, maximum output current is 2.0mA); The remote indicator does not illuminate in normal and flashes in alarm.
Class and Setup	Classes A1R, A2S, BS programmable.
Maximum Ripple Voltage	2V (peak-to-peak)
Alarm Reset	Instantaneous cut-out (10s Min, 1.0VDCMax.)
Wiring	Polarized two wire
Ingress Protection Rating	IP2X
Ambient Temperature	Class A1: -10℃~+50℃ Class A2: -10℃~+50℃ Class B: -10℃~+65℃
Typical Fixed Temperature	Class A1: 58℃ Class A2: 62℃ Class B: 77℃
Relative Humidity	≤95%, non-condensing
Material	ABS
Dimensions	Diameter: 100mm Height: 53.3mm (with base)
Mounting Hole Spacing	45mm~75mm
Weight	About 110g (with base)

Accessories and Tools

Module	Name	Remarks
P-9910B	Handheld Programmer	Order separately
DB-01	Base	Order separately
DB-01D	Base	Order separately
DP-9907	Active End of Line Unit	Order separately
T-MT	Commission Tool	Order separately

WEEE Information



2012/19/EU (WEEE directive): Products marked with this symbol cannot be disposed of as unsorted municipal waste in the European Union. For proper recycling, return this product to your local supplier upon the purchase of equivalent new equipment, or dispose of it at designated collection points.

Limited Warranty

GST warrants that the product will be free from defects in design, materials and workmanship during the warranty period. This warranty shall not apply to any product that is found to have been improperly installed or used in any way not in accordance with the instructions supplied with the product. Anybody, including the agents, distributors or employees, is not in the position to amend the contents of this warranty. Please contact your local distributor for products not covered by this warranty.

This Data Sheet is subject to change without notice. Please contact GST for more information or questions.

Gulf Security Technology Co., Ltd.

30309289

No. 80, Changjiang East Road, QETDZ, Qinhuangdao, Hebei, P. R. China 066004

Issue 1.06

Tel: +86 (0) 335 8502434 Fax: +86 (0) 335 8502532

service.gst@fs.utc.com www.gst.com.cn