

FIRE EXTINGUISHER CABINET 6 kg



External dimensions (mm): h620xw335xd240
Internal Dimensions (mm): h550xw244xd204
Weight (kg): 2.4
Ring Diameter (mm): 150/170

Quantity per pallet (n°): 60
Pallets dimensions (cm): h122xw97xd265
Pallet Weight (kg): 175

TECHNICAL FEATURES

Material: polypropylene, nylon, polycarbonate
Production Process: Injection Molding
Label with company logo

COMPONENTS

- Label in PVC
- Inspection window in polycarbonate
- Nylon clamping ring with PVC spring

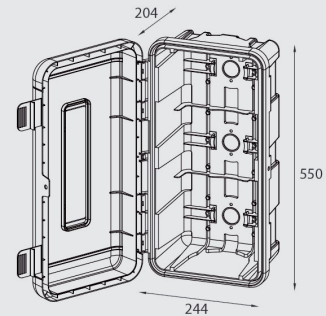
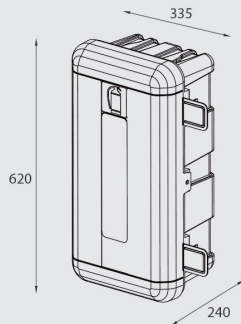

TEST AND CERTIFICATIONS

- TÜV RHEINLAND (7/2012) (IP certificated)

PRODUCT FEATURES

- 1 Double ergonomic handles integrated in the lid, with click-system anti-vibration for security in the everyday use
- 2 The Inspection window allows the view of the fire extinguisher. The "OR" seal guarantees a better water-resistance
- 3 Lockable against burglary or mishandling with a common padlock or with seal
- 4 Labyrinth system against water ingress. Even without seal is it guaranteed against dust and water ingress
- 5 Extinguisher holding kit composed of: PVC clamping spring with 4 holes, and Nylon clamping ring available in two sizes
- 6 Bayonet cap for clamping ring, with reinforced fixing points easy to assemble without any tools
- 7 PVC label (optional) 8x8 cm with extinguisher pictogram and/or company logo according to the law of the country of destination



OPTIONALS

Brackets: 88041, 88042
OPTIONS: Custom resin labels (pictogram and logo)

SPARE PARTS: 89515, 89507, 89506, 89508