

XP95

Addressable Door Retainer (ADR)



Product overview

Product	Addressable Door Retainer
Part No.	55000-982APO
Digital Communication	XP95 compatible

Product information

Door retainers ensure buildings are accessible for all by holding fire doors in the open position then releasing and closing them according to the fire system design. The Apollo ADR is an XP95 device designed for installation directly onto an addressable loop and is suitable for use on all types of fire door, including critical actuation doors.

- Integrated loop isolator
- Extra low voltage usage
- Suitable for critical actuation (Category A) installations*
- Failsafe by design
- Patented permanent magnet technology
- Doors and zones can be individually controlled
- 200N holding force rating
- Surface or semi-flush wall mounted
- Floor mounting options via standard bracket

*When connected to a compliant panel

Manufacturer's Specification

All data is supplied subject to change without notice. Specifications are typical at 24 V, 25°C and 50% RH unless otherwise stated.

Supply voltage	17 V to 28 V dc								
Digital communication	XP95 compatible								
Modulation Voltage	5 V - 9 V								
Current Consumption Switch ON Surge and Quiescent	3.7 mA Max								
EDL	4								
Rated Holding Force	200 N								
Initialisation and Self-Check Time (typical)	45 minutes								
Typical Release-Hold Cycle	8 seconds (will release within 3 seconds)								
Status Indicator*	<table border="0"> <tr> <td>Flashing Amber</td> <td>Every 5s - Charging</td> </tr> <tr> <td>Flashing Green</td> <td>Every 5s - Normal (Charged)</td> </tr> <tr> <td>Continuous Amber</td> <td>Isolator Active State or Fault (Charged)</td> </tr> <tr> <td>Flashing Amber</td> <td>Every 1s - Isolator Active State or Fault (Charging)</td> </tr> </table>	Flashing Amber	Every 5s - Charging	Flashing Green	Every 5s - Normal (Charged)	Continuous Amber	Isolator Active State or Fault (Charged)	Flashing Amber	Every 1s - Isolator Active State or Fault (Charging)
Flashing Amber	Every 5s - Charging								
Flashing Green	Every 5s - Normal (Charged)								
Continuous Amber	Isolator Active State or Fault (Charged)								
Flashing Amber	Every 1s - Isolator Active State or Fault (Charging)								
Operating temperature	0°C to + 40°C								
Standards and Approvals	EN 1155:1997 + A1:2002, EN 54-17:2005, EN 54-18:2005, CPR								
IP Rating	IP3X								
Dimensions	87.9mm wide x 87.9 high x 83.5mm deep								
Weight	515 g								
Materials	Housing: White flame-retardant ABS								
<i>*under normal operation</i>									

Application

Direct connection to the fire panel makes the ADR a Category A fire door retainer, as defined in BS7273-4 providing the panel has supporting BS 7273-4 Category A functionality.

The addressable functionality allows panel cause & effect programming in complex buildings that facilitates evacuation whilst closing fire doors in alarmed areas. All doors or zones of doors can be closed automatically by the control panel or a dedicated input/output switch to enable a lockdown strategy in schools, colleges, courts & custodial.

Patented permanent magnet technology results in minimal current being required to hold doors open.

The ADR has twin LEDs to indicate Normal, Charging, Loop Isolator Activation and Device Fault Statuses.

Device Fault conditions include:

- Loss of protocol communication
- Insufficient loop power to charge.

All information in this document is given in good faith but Apollo Fire Detectors Ltd cannot be held responsible for any omissions or errors. The company reserves the right to change the specifications of products at any time and without prior notice.

The unit is supplied with a manual release switch and is programmable to operate under failsafe conditions.

Installation

Decide on suitable mounting positions for the magnet and the keeper plate. The magnet should be at least 600 mm from the axis of the door hinge. The manual release switch should be easily accessible when the door is retained open.

Fit the door holder back box to the wall. This door holder can be used in semi-flush mounting or surface mounting applications. Check that any fixings used are strong enough to withstand the holding force of the door retainer.

Run the fire system loop wires (0.2mm² - 3.3mm²) through the back box and connect to the rear of the door retainer as per the Connections diagram. We recommend using cable glands (20mm) with fire cable in harsh environments. Fit the door holder to the back box with the screws supplied to a torque of 0.5Nm.

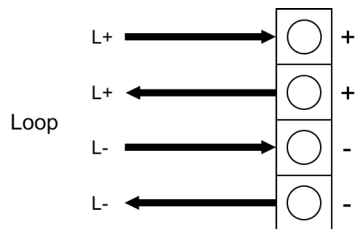

Check that the rubber ring is fitted in the base plate before fitting the keeper plate assembly loosely to the door. Adjust the angle to align with the magnet and tighten the mounting screws to lock the plate in place.

Do not use the door retainer until sufficient initialisation and self-check time has elapsed. The device may not actuate until the device is sufficiently charged.

Device Addressing

The 7-bit address is set using a DIL switch. Failsafe is enabled by switch 8.

1	2	3	4	5	6	7	8
Sets the address							Failsafe Enable

Please see BS7273-4 Code of practice regarding failsafe operation.

Example:

Address	DIL Switch (1234567)
1	1000000
85	1010101
126	0111111

Isolator Specification

V _{SO} , Isolate Voltage	13-16V
V _{SC} , Reconnect Voltage	12-14V
I _C , Continuous Current—Switch Closed	1A max
I _S , Switching Current	3A max
I _L , Leakage Current	300µA max

Conditions for Holding

The door will hold if all the following conditions are met:

- There is loop communication
- The device is sufficiently charged (45 minutes)
- No faults on the device
- The device has a valid address (not 0 or 127)
- There is no Alarm condition indicated by the panel

Maintenance

Fire door holders should be tested weekly as part of the fire-system test procedures. For optimum holding force, the face of the magnet and keeper plate should be kept clean and free from damage. To comply with BS EN 1155, this device should not be used to hold open a door at less than 65°.

There are no user-serviceable parts in this door retainer.

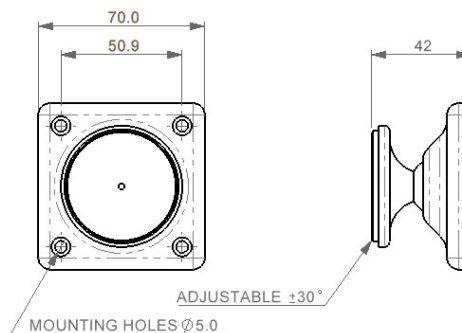
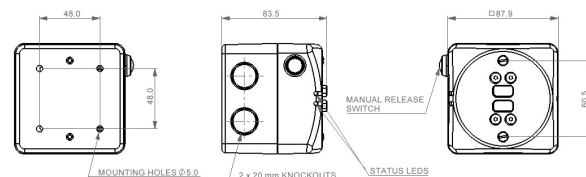

EMC Directive

The ADR complies with the essential requirements of the EMC Directive 2014/30/EU, provided that it is used as described in this data sheet.

Construction Products Regulation (EU) 305/2011

The ADR complies with the essential requirements of the Construction Products Regulation (EU) 305/2011

